

## Monitor Arm – Gas Dual Arm

Model #HWS-S200

Leadtime: 3 weeks

Warranty: 5 years

- Free movement arm for a dual monitors provides unlin for optimal ergonomic comfort
- Constant force function (gas cylinder) allows easy adju
- Eiither monitor can be adjusted separately without inte

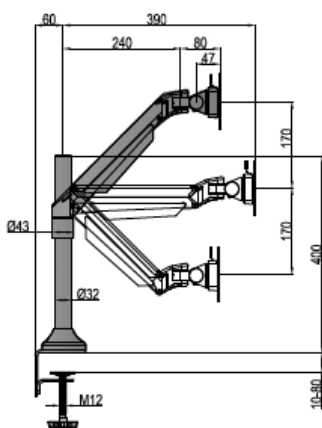

Product Dmlensons

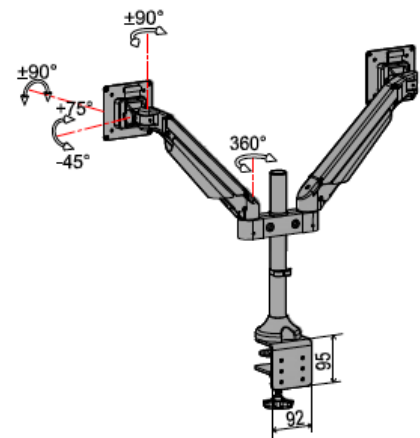
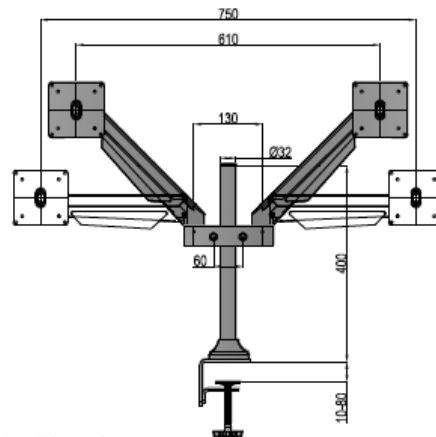

Multifunctional adjustment figure

Technical parameter											
										Desk thickness application (mm)	
LCD Size	Wt.Capacty(kg)	Lift(mm)	Tilt	Swivel	Pivot	VESA	Packing size(mm)	NW (kg)	GW(kg)	Thru desk	desk clamp
24"	2-10	340	+75° ~ -45°	± 90°	± 90°	75*75	Inner:540*220*145	Inner: 6	Inner: 6.5	30	80
	100*100					Outer:565*235*455	Outer:18				

HWS Hong Kong Ltd

39/F China Online Center, 333 Lockhart Road, Wanchai, Hong Kong Tel 852 2832 0210